

FLEX-LIFTER™

Conveyor Belt Lifter

A Tough, Versatile Beltline Tool

Lifting a tensioned conveyor belt out of the way to do maintenance work is a difficult job. It can be time-consuming and dangerous. The Flex-Lifter™ makes the job safer and easier. It takes on the toughest jobs, like lifting a belt even when it is tensioned up to the stated ratings. This tool is versatile. Adjustable wings make it easy to lift troughed or flat topside belts.

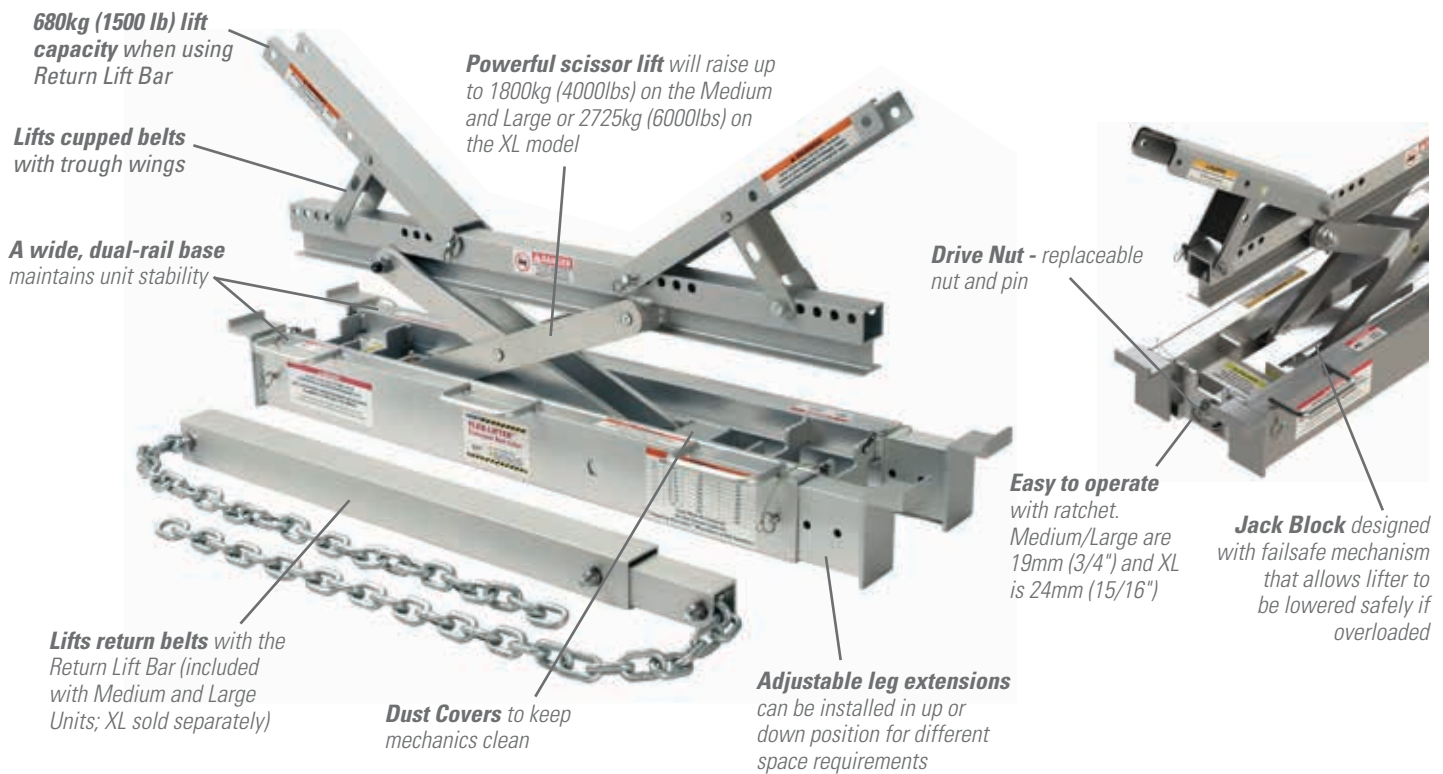

Features and Benefits

- **Easy to use.** The Flex-Lifter™ is easily operated with a manual ratchet. And, if used with caution so as not to overdrive, the Flex-Lifter may be used with a drill motor or impact wrench.
- **Works on a range of conveyors.** The Medium model is for belt widths 900-1500mm (36"-60"), the Large model is for belt widths 1200-1800mm(48"-72"), and the XL model is for belt widths 1800-2400mm (72"-96"). Lifts flat or cupped belts with ease.
- **Safe.** Features a wide, dual-rail base and high lift capacities. Also designed to work with standard CEMA and common underground conveyor structure and idler types.
- **Transportable.** The tool can be carried to the job site and easily placed into position on the conveyor structure. Also available with cart feature for rolling the unit.
- **Won't damage the belt.** Lifts the belt from underneath. Does not clamp onto the belt's edges or cover.

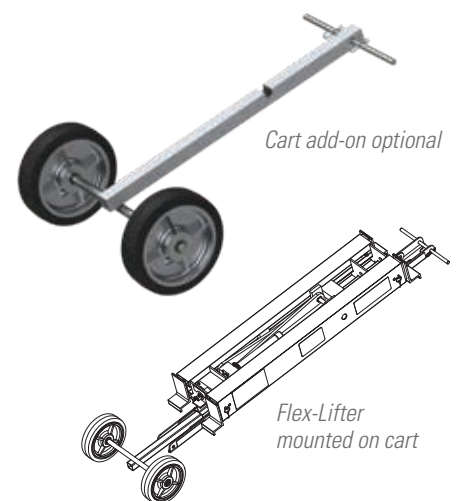

FLEX-LIFTER™ Conveyor Belt Lifter

Specifications and Guidelines

Specifications						
Sizes	Belt Width Range	Conveyor Span		Weight	Closed Height	Vertical Lift
		MIN	MAX			
Medium	900-1500mm (36"-60")	1047.8 mm (41.25")	1936.8 mm (76.25")	29.9 kg (66 lb.)	169mm (6.75")	350mm (14")
Large	1200-1800mm (48"-72")	1301.8 mm (51.25")	2190.8 mm (86.25")	35.4 kg (78 lb.)	169mm (6.75")	400mm (16")
XL	1800-2400mm (72"-96")	1816.1 mm (71.50")	2704.3 mm (106.47")	58.1 kg (128 lb.)	188mm (7.5")	400mm (16")
Return Lift Bar (Medium)	900-1500mm (36"-60")	-	-	11.3 kg (25 lb.)	n/a	n/a
Return Lift Bar (Large)	1200-1800mm (48"-72")	-	-	22.6 kg (50 lb.)	n/a	n/a
V-Return Lift Bar (XL)	1800-2400mm (72"-96")	-	-	28.6 kg (63 lb.)	n/a	n/a

Safe Lifting Capacity (Medium and Large models)			
Height		Max. Weight	
mm	in.	kg	lb.
0 - 25	0 - 1	225	500
25 - 50	1 - 2	450	1000
50 - 75	2 - 3	675	1500
75 - 100	3 - 4	900	2000
100 - 125	4 - 5	1150	2500
125 - 150	5 - 6	1350	3000
150 - 175	6 - 7	1600	3500
> 175	> 7	1800	4000

Safe Lifting Capacity (XL model)			
Height		Max. Weight	
mm	in.	kg	lb.
0 - 25	0 - 1	500	1100
25 - 50	1 - 2	815	1800
50 - 75	2 - 3	1140	2500
75 - 100	3 - 4	1450	3200
100 - 125	4 - 5	1680	3700
125 - 150	5 - 6	2090	4600
150 - 175	6 - 7	2400	5300
> 175	> 7	2725	6000

Ordering Information

Flex-Lifter Conveyor Belt Lifter			
Description	Ordering Number	Item Code	Wt. Kg
Medium Flex-Lifter 900-1500mm (36"-60")	FL-M	76469	29.9
Large Flex-Lifter 1200-1800mm (48"-72")	FL-L	76470	35.4
XL Flex-Lifter 1800-2400mm (72"-96")	FL-XL	76983	58.1
Return Lift Bar - Medium	FLRLB-M	76482	11.3
Return Lift Bar - Large	FLRLB-L	76481	22.6
Return Lift Bar - XL	FLVRL-XL	76984	28.6
Flex-Lifter Cart	FLCK	77729	9.0

Aluminum Content Flex-Lifter		
Aluminum Alloy Type	Percent	
	Mg Magnesium	Ti Titanium
4043	0.05%	0.2%
5356	5.5%	0.2%
6005	0.6%	0.1%
6061	1.0%	-
6063	0.7%	-
7075	2.5%	-



Authorized Distributor:

240 Macpherson Road • #02-01 • Singapore 348574
Tel: +65-6484-1533 • Fax: +65-6484-1531 • E-mail: asiasales@flexco.com

Visit www.flexco.com for other Flexco locations and products.

©2019 Flexible Steel Lacing Company. 07/31/19. For reorder: X2815

